

CANDIDE

A fieldbus system to control detector front-end electronics.

W.P.J.Heubers, R.G.K.Hart, H.Boterenbrood, P.Rewiersma, I.Weaverling
NIKHEF, National Institute for Nuclear and High-Energy Physics
P.O.Box 41882, 1009 DB Amsterdam, The Netherlands

The CANDIDE system is developed to control and monitor the front-end electronics of a subdetector prototype for the ATLAS inner tracker. CANDIDE is based on the Controller Area Network (CAN), which is developed by Bosch from Germany for the automotive industry. Low cost, reliability and real-time capabilities were important issues to select this fieldbus for the control of the front-end electronics. Prototype CAN nodes, based on the Philips 80C592 micro controller, has been built to control functions such as setting discriminator thresholds, masking noisy channels and monitoring temperature sensors of the channels in the ATLAS subdetector. This paper describes the implementation of a network of these prototype CAN nodes. Additionally, the integration of a generic fieldbus controller into the Cortex distributed control system (CICERO project) is shortly discussed.

1. Introduction.

ATLAS is a high-energy physics detector to be used in the Large Hadron Collider at CERN and planned to be operational around the year 2004. At this moment the detector control system for the ATLAS project is in the phase that user requirements are captured. Prototypes are built and tested in the laboratories and in test beam runs at CERN.

Chapter 2 outlines shortly the organization of a detector control system and in some more detail the subsystem for the front-end controls. In chapter 3 a description is given of the Controller Area Network (CAN) and chapter 4 presents the CANDIDE system, based on this fieldbus. Paragraph 4 outlines a contribution to an R&D project initiated by

CERN [1], concerning the definition of a generic fieldbus controller that has to be integrated into the Cortex (object-oriented) control system.

2. Detector control.

From a control system point of view the ATLAS detector is a large scale system, that can be described as a set of devices, such as the inner tracker detector, the calorimeter, the muon detector and systems like the data acquisition system and the gas system. Each of these devices and systems can be decomposed into subsystems with their own functionality and degree of autonomy. This hierarchical organization of the detector control system is illustrated in figure 1.

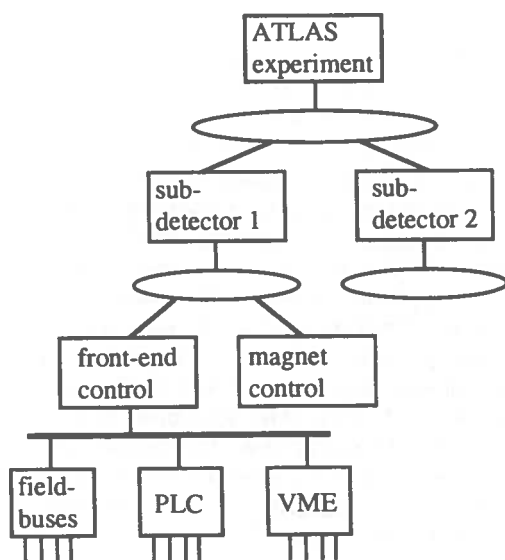

Fig. 1. An example of the hierarchical organization of a detector control system.

For each subdetector (device) the control and monitoring of the front-end electronics can be considered as a subsystem of the overall detector control system. In case of malfunctioning of the front-end electronics, an alarm generated by this subsystem must be reported to the detector control system. Typical for each channel (or set of channels) in the detector, slow control functions, such as setting a discriminator threshold or masking noisy channels, could be implemented. Besides these control commands, it is necessary to monitor continuously the status of certain parameters in the front-end system (e.g. voltage trip levels and temperature), which generates possible alarms. The number of detector channels in a high-energy physics detector like ATLAS can be very large. Depending on the type of (sub)detector several thousand (sets of) channels, geographically distributed in the detector, have to be controlled and monitored.

The environment in which the front-end electronics operates, puts special requirements to the system. The detector is only accessible during maintenance periods. This puts demands on the reliability and fault-tolerance of the control system.

The control path must be redundant and independent from the functioning of the data acquisition system itself. Another important constraint concerns the radiation. This is especially a problem in the inner part of the detector where all electronic components must be radiation hard.

3. The CAN fieldbus.

A fieldbus or serial bus is in principle an industrial communication network to which a number of geographically distributed nodes are connected. Fieldbuses are meant for low level equipment control functions like monitoring sensors and controlling actuators. The fieldbus network is able to transport relatively small messages in a fast and reliable way to exchange information between the different nodes. Fieldbus nodes often have some degree of local intelligence, implemented in a micro controller chip, in a PLC system or even in a PC. Low-cost, compactness, reliability and real-time capabilities (that is response times are short and deterministic) are important features for selecting a fieldbus system. See reference [2] for a tutorial on fieldbus applications in physics laboratories.

The CAN (Controller Area Network) fieldbus was selected for the controls of a prototype subdetector for ATLAS. The CAN fieldbus was developed by the German company Bosch, initially

for the automotive industry, but nowadays CAN is used extensively in industrial fields as well. One major reason to select CAN was that the first two layers of the ISO/OSI reference model are available as an open industrial standard as defined in ISO/DIS 11898 [3]. This standard does not cover the transmission medium (twisted pair, optical fiber) and the transmission speed (between 5 Kb/sec and 1 Mb/sec, depending on distance and medium). The CAN protocol specifications define multi-master mode, multicasting, a message priority scheme and a high degree of fault-tolerance. Integrated circuit manufacturers like Philips, Motorola and Siemens offer both stand-alone protocol controller IC's and integrated protocol controllers on a micro controller chip.

The application layer of the ISO/OSI reference model is covered by the CAN Application Layer CAL [4]. The layers between the datalink layer and the application layer are not implemented in fieldbus networks due to performance reasons, although management control functions available with CAL do offer services concerning network management, layer management and identifier distribution (figure 2).

The CAL application layer defines a set of services, called CAN-based Message Specification (CMS). With CMS the applications can specify CMS-objects like variables, events and domains and specify services upon these objects like 'write variable', 'notify event' or 'download segment'. CMS is derived from the ISO/IEC 9506 standard MMS, an application layer standard designed for the remote control and monitoring of industrial devices (such as PLC's).

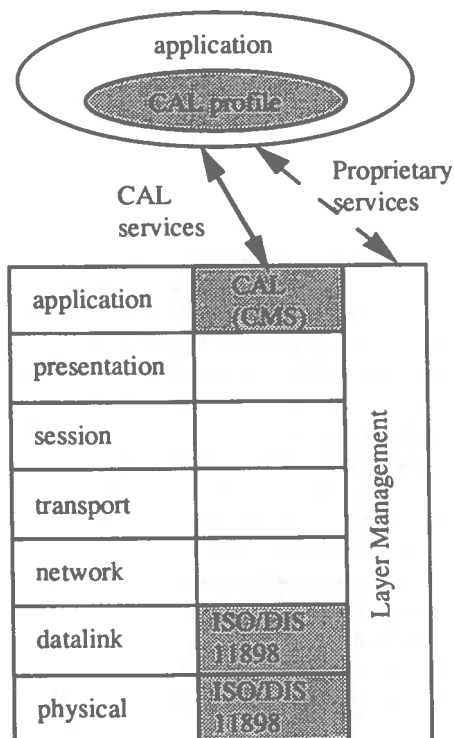

Fig.2 The CAL reference model.

4. CANDIDE.

CANDIDE (a CAN Divers Interface for Detector Electronics) is developed to control and monitor the front-end electronics of prototype micro-strip gas counters (MSGC). It was foreseen that the forward trackers of the ATLAS detector would be partly implemented with MSGC's¹.

A general-purpose CAN node GPCAN [5] has been designed around the P87C592 micro controller from Philips and has been implemented as a piggyback board. This micro controller includes EPROM and RAM memory, a CAN protocol controller, a 10-bit ADC with 8 multiplexed outputs, two 8-bits PWM outputs and five 8-bit I/O ports. The piggyback card is placed on a GPCAN motherboard, that contains additional functionality such as a serial DAC and a CAN bus connector. A PC with a CAN controller from Softing GmbH was used for the development of the system. The configuration to be used in the test beam runs was hosted by a Sun workstation

¹Recently the ATLAS collaboration took the decision to use silicon strip detectors instead of MSGC's.

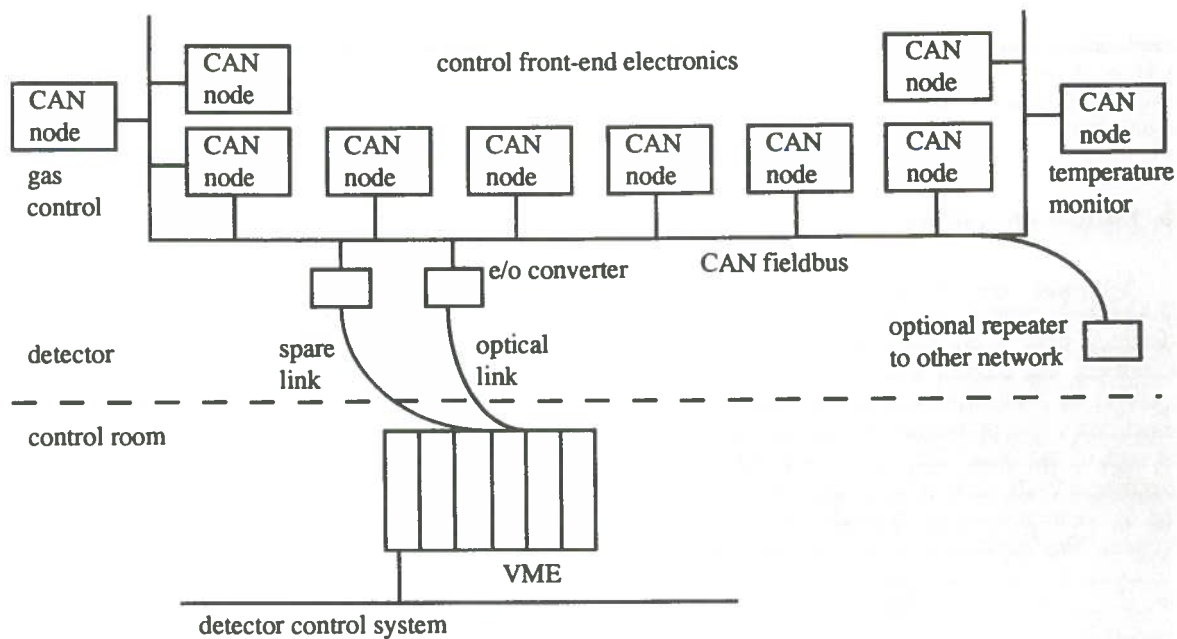

Fig. 3 Detector front-end control with a CANDIDE fieldbus system.

interfaced by a CV002 VME module from MicroSys Electronics GmbH. The VME module is connected to the actual CAN network by an optical link as is shown in figure 3.

The application software is not implemented with the CAL standard, but instead a custom-made message format was defined, with a maximum frame length of 130 bits. With a transmission speed of 125 Kb/sec on the bus this resulted in a maximum transfer time of 1.04 msec per message.

5. Integration in the control system.

As outlined in figure 1, the fieldbus networks are used for low-level, real-time control of the detector front-end electronics. In a large detector control system as needed for the ATLAS detector, it is foreseen that both fieldbuses and PLC systems will play an important role in the low-level control of other parts of the detector system as well (e.g. vacuum and magnet systems). Although the aim is to apply within the scope of this project as much as possible 'standardized systems', it is hardly to avoid that for different subsystems different PLC and fieldbus systems will be preferred, because of complexity and time scale constraints. The control system must be able to integrate these heterogeneous subsystems into the overall detector control system.

CICERO is a research project from CERN [1], that will outline and provide the main building blocks of a generic control information system in order to reduce costs and maintenance efforts of future experiments at CERN. The CICERO group has designed and (partially) implemented an integration framework ('software bus') called Cortex [6]. The responsibility of this Cortex system

is twofold: an off-line part in which the configuration of the control system is described and an on-line part where information and commands must be distributed to the components of the system. Cortex has to be flexible enough to support the addition or removal of components without deteriorating the operation of the system. For this purpose Cortex maintains a repository to handle the logical description of the architecture and to describe the exchange of information between the different components.

Industrial fieldbus and PLC systems often come with their proprietary configuration tools. Most of these tools use a graphical editor to design the fieldbus or PLC configuration and to generate files that contain tables with the configuration information. At this moment there is no standard available for the configuration formats of fieldbus and PLC systems, as there is no general accepted standard available which specifies the application interface. Although in some cases suppliers publish their interface specifications and make them available as an open standard to other suppliers. Examples of these are the ISO/DIS 119898 standard that defines the Can Application Layer for the CAN fieldbus and the ISO/IEC 9506 standard that specifies the Manufacturing Message Specification for PLC systems.

Work has started to design a generic fieldbus controller for the object-oriented Cortex system as it is defined by CICERO. From this generic or virtual controller, other controllers can be derived for specific fieldbus implementations. These derived controllers will inherit attributes and methods as they are defined by the generic fieldbus controller. One interesting topic in this respect is how to convert the proprietary configuration formats into the Cortex repository. As far as the

application layer concerns, the Can Application Layer CAL is a good candidate for the implementation of a prototype Cortex fieldbus controller.

6. Future directions.

Although the initial application for the CANDIDE system, the micro-strip gas counter detector, part of the inner detector of ATLAS is canceled, the project will continue. A modified version of CANDIDE will be built to control the electronics of a prototype of a muon detector, that is part of the outer detector of ATLAS. For this purpose a CAN node is developed that can control up to 16 high-voltage channels in the front-end system. The intention is to interface the application software for this prototype using the CAN-based Message Protocol CMS as defined in the standardized Can Application Layer CAL.

A study on the integration of these fieldbus application into the higher-level layers of the control system will continue within the framework of the CICERO research project.

7. Conclusions.

The use of an industrial fieldbus to control the front-end electronic system of a large detector like ATLAS seems to be a good choice because of its reliability, its compactness, its low-cost and because of the industrial support. The design constraint to separate the data path from the control path can be easily achieved by implementing a fieldbus network. The CAN fieldbus is an excellent choice, not only for its reliability and its real-time capabilities, but also because its availability as an open standard. The CAN application layer provides a complete and well-defined interface to access and manage the fieldbus network configuration. One point not resolved yet, concerns the radiation hardness of the industrial available micro controllers. Especially in the inner parts of ATLAS radiation hardness is a major issue.

References.

- [1] J.M.Le Goff et al. CICERO: Control Information system Concepts based on Encapsulated Real-time Objects. 1994 Status Report. CERN/LHCC 95-15 LCRB status report / RD 38
- [2] R.Rausch, CERN. Tutorial on standard fieldbuses applications in physics laboratories. Invited tutorial paper ICALEPS '93
- [3] Road vehicles - Interchange of digital information - Controller area network (CAN) for high-speed communication. International

Standard Organization. Reference number ISO 11898:1993(E)

- [4] Konrad Etschberger CAN, Controller Area Network Grundlagen, Protokolle, Bausteine, Anwendungen ISBN 3-446-17596-2
- [5] ATLAS MSGC Support Document for the Micro Strip Gas Counter Sub-system. ATLAS internal note, INDET-NO-076, 15 December 1994
- [6] R.Barillere et al. The Cortex project. A quasi real-time information system to build control systems for high-energy physics experiments. Proceedings ICALEPS'93

ICALEPCS 1995

Chicago